

RPS-0106 01/02

IMPORTANT RECEIVING INSTRUCTIONS

Visually inspect all components for shipping damage. If shipping damage is found, notify carrier at once. Shipping damage is NOT covered by warranty. The carrier is responsible for all repair and replacement costs resulting from damage in shipment.

SAFETY ISSUES

IMPORTANT – USER SAFETY AND PROTECTION: In setting up systems to fit your operations, care must be taken to select the proper components and design to insure appropriate that all safety measures have been taken to avoid the risk of personal injury and property damage from your application or system.

GARDNER BENDER IS NOT RESPONSIBLE FOR DAMAGE OR INJURY CAUSED BY UNSAFE USE, MAINTENANCE OR THE APPLICATION OF ITS PRODUCTS. Please contact Gardner Bender for guidance when you are in doubt as to the proper safety precautions to be taken in designing and setting up your particular application.



B4500K Blower Kit



B3000 Blower for B60



BV208DA Blo-Vac™

1.0 Description	2	7.4 Power Saver™ Line Packages	5
2.0 Safety Symbol Definitions	2	7.5 Tag-Along™ Line Packages	5
3.0 Warnings	2	7.6 PL Series Pull Line	5
4.0 Grounding Instructions	3	7.7 Seal-Offs	6
5.0 Technical Specifications	3	7.8 Line Carriers	7
6.0 Product Description	3	7.9 Blowing or Vacuuming Thru Conduit	8
7.0 Use and Operation	4	8.0 Maintenance	10
7.1 Blowing Line in Conduit	4	9.0 Jetline® Systems	10
7.2 Preparation	4	9.1 B4500K Line Shooter™ Blowing System	11
7.3 Selecting the Pull Lines	4	9.2 B60 Super Blower™ System	12

1.0 DESCRIPTION

The GB/JetLine® Blower and Blo-Vac™ Systems are low pressure tools that deliver high volume air stream, which is used to place pull line in most conduit from ½" to 6" diameter.

Blo-Vac™ systems are intended for commercial use only. The systems are convenient to use in new and existing construction. They require a 120 V, 60 Hz grounded power source. See 5.0 Technical Specifications, GB/JetLine® Blowers Table and GB/JetLine® Blo-Vac™ Table.

The Blower or Blo-Vac™ System consists of four basic components:

- The Power Unit – a high volume air or vacuum source.
- Hose and Seal-Off – to channel the air into the conduit and form a seal at the conduit entrance.
- A Line Carrier – to serve as a movable object that supplies the pulling force to install pull line in conduit.
- Pull Line – for pulling wire through the conduit, to pull rope or cable for large or difficult runs.

A thorough understanding of all components and their functions and operating precautions is essential for safe and efficient use of the system.

Read and understand all the instructions before attempting to use the system or blow line into conduit.

2.0 SAFETY SYMBOL DEFINITIONS

The symbol below is used to call your attention to instructions concerning your personal safety. Watch for these symbols. They point out important safety precautions. They mean **“ATTENTION! Become alert. Your personal safety is involved.”** Read the message that follows and be alert to the possibility of personal injury or death.

 **DANGER:** Indicates a high probability that death, severe bodily injury or major property damage could result.

 **WARNING:** Is serious but less inevitable. There is some probability that death, severe bodily injury or major property damage could result.

 **CAUTION:** Is less serious but still demands attention. Indicates a hazard which may result in minor injury or property damage.

3.0 WARNINGS

This section contains information for your protection, safety and quick reference. When using an electrical appliance basic precautions should always be followed, including the following.

Read all Instructions before using the Blo-Vac™ System.

 **CAUTION:** Do not leave the Blo-Vac™ when plugged in. Unplug from outlet when not in use and before servicing.

 **CAUTION:** To reduce the risk of electrical shock: Do not expose to rain. Store indoors.

 **CAUTION:** Use only as described in this manual. Use only manufacturer's recommended attachments.

 **WARNING:** Do not use with damaged cord or plug. If the Blo-Vac™ is not working as it should, has been dropped, damaged, or dropped in water, return it to a service center.

 **CAUTION:** Do not pull or carry by cord, use cord as a handle, close a door on cord, or pull around sharp edges or corners. Do not run the Blo-Vac™ over cord. Keep cord away from heated surfaces.

 **WARNING:** Do not unplug by pulling on cord. To unplug, grasp the plug, not the cord.

 **CAUTION:** Do not handle plug or Blo-Vac™ with wet hands.

 **CAUTION:** Do not put any object into openings. Do not use with any opening blocked: keep free of dust, lint and anything that may reduce air flow.

 **WARNING:** Keep hair, loose clothing, fingers and all parts of body away from openings and moving parts.

 **WARNING:** Do not pick up anything that is burning or smoking, such as cigarettes, matches, or hot ashes.

 **CAUTION:** When used for vacuum clean-up, do not use without filter bag in place.

 **CAUTION:** Turn off switch before unplugging.

 **DANGER:** Do not use to pick up flammable or combustible liquids such as gasoline. Do not use in areas where they are present.

 **WARNING:** Use extra caution when working on a ladder, elevated platforms, stairs, etc.

 **WARNING:** Do not use the power unit in a manhole — keep the power unit above ground.

 **DANGER:** All GB/JetLine® conduit fishing Blo-Vac™ systems are designed to force loose debris of all types out of the conduit by means of a pressurized force. Serious or critical injury may result to anyone struck by high velocity debris or the line carrier. Warn all personnel to stand clear of the conduit exit prior to pressurization procedures or blowing line into the conduit.

 **CAUTION:** GB/JetLine® Blo-Vac™ Systems have been designed specifically for fishing conduit. The system, under certain field conditions, may be used to remove debris or water from the conduit. The electric motor is protected from liquid entering the fan area by a float ball. If liquid is discharged, the float ball has been defeated. Immediately unplug unit from power source and check to make sure the float ball is functioning properly and the sealing area is free of foreign matter.

 **DANGER:** Failure to observe these instructions or misuse of equipment could result in serious injury or possible death.

4.0. GROUNDING INSTRUCTIONS

The GB/JetLine® blowers and Blo-Vac™ systems require a 120 V, 60 Hz, 15 A circuit; with the exception of the B3000 power unit which requires a 120 V, 60 Hz, 30 A circuit; and must be grounded. If the power unit should malfunction or breakdown, grounding provides a path of least resistance for the electrical current to reduce the risk of electrical shock. These power units are equipped with a cord that has a grounding conductor and grounding plug. The plug must be inserted into an outlet that is properly grounded in accordance with all codes and ordinances. See Figure 1.

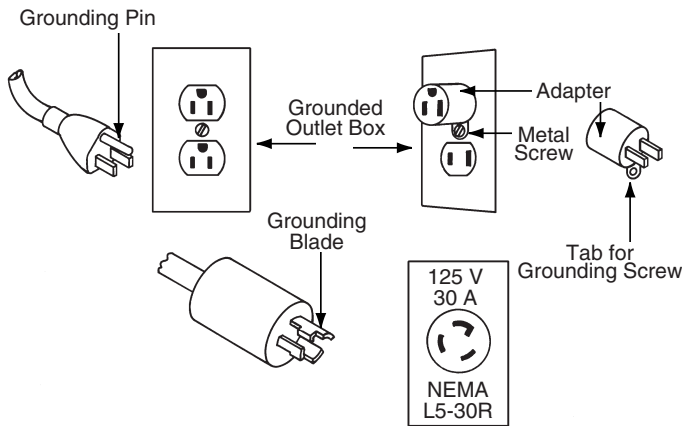

Figure 1. Grounding Methods

⚠ CAUTION: Improper connection of the equipment grounding conductor can result in a risk of electrical shock. Check with a qualified electrician or service person if you are in doubt as to whether the outlet is properly grounded. Do not modify the plug provided with the Blo-Vac™. If it will not fit the outlet, have the correct outlet installed by a qualified electrician.

5.0 TECHNICAL SPECIFICATIONS

GB/JetLine® Blowers		
	B4500K	B60
Power Unit	1261	B3000
Voltage	120	120
Frequency	60 Hz	60 Hz
AMPS	7.50	23
In. Water Lift (sealed)	85-92	85-92
P.S.I.	3.31	3.31
CFM	90	270
No. of Motors	1	3
Impeller Stages (Fans)	2	2
Thermal Overload	Yes	Yes
Motor Type (Cooling)	Flow Through	Flow Through
Handling	Portable	Portable
Weight	7.5 lb	35 lb
Hose Dia. (Inch)	1½	2½
Length (Feet)	3	25

GB/JetLine® Blo-Vac™	
	BV208DA
Power Unit	1523
Voltage	120
Frequency	60 Hz
AMPS	13.8
Inches Water Lift (sealed)*	130-135
P.S.I.*	4.86
CFM	92
No. of Motors	1
Impeller Stages (Fans)	3
Thermal Overload	No
Motor Type (Cooling)	By-Pass
Handling	Cart
Recovery Cap. (Gals)	9**
Height with Cart (Inch)	41
Motor Brush Life (Hours)	750
Weight	50 lb
Hose Dia. (Inch)	1½
Length (Feet)	8
* Will vary with voltage and atmospheric conditions.	
** When using recovery compartment and tool storage compartment together.	

6.0 PRODUCT DESCRIPTION

GB/JetLine® Blowers and Blo-Vac™ systems are designed to provide a convenient means of installing pull line in a “sealed” conduit. “Sealed” conduit for this purpose is considered EMT conduit with compression type couplings, rigid conduit with threaded joints, or PVC conduit with adhesive bonded joints. Conduit with set screw type couplings does not effectively seal joints and substantial air or vacuum loss occurs making it difficult to maintain pressure or vacuum to place a line in the conduit.

Blower Systems

GB/JetLine® supplies two blower systems; the B4500K Line Shooter™ (for fishing from ½" through 4" trade size conduit) and the B60 Super Blower™ for heavy duty work in conduit from 2½" through 6". See Figures 2 and 3.

B4500K Line Shooter™

The B4500K Line Shooter™ conduit fishing kit is equipped with a light weight 1261 Power Unit, three foot hose, shoulder strap, power saver line packages, foam line carriers, inflatables and accessories for fishing conduit from ½" through 4". Bulk pull line is not included with the kit.

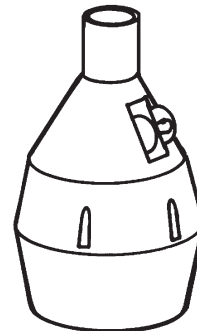

Figure 2. 1261 Blower

B60 Super Blower™

The B60 Super Blower™ was designed for use in long underground single bore conduit from 2½" through 6". The B3000 Power Unit must remain above ground for safety reasons, and the 2½" diameter x 25' long hose and seal-off are used in the manhole. The portable triple motor power unit provides a high volume of air to blow a line in large bore conduit whether above ground or below ground.

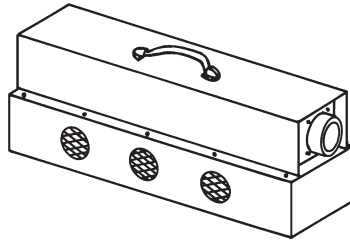

Figure 3. B3000 Super Blower

Blo-Vac™ Systems

GB/JetLine® Blo-Vac™ Systems: BV208DA Super-Ultra Blo-Vac™ provides blowing or vacuuming capabilities for conduit fishing of ½" through 6". These systems provide a higher output pressure for more difficult runs. The water lift capabilities of the Blo-Vac™ is the same for blowing or vacuuming. See 5.0 Technical Specifications, GB/JetLine® Blo-Vac™ Table.

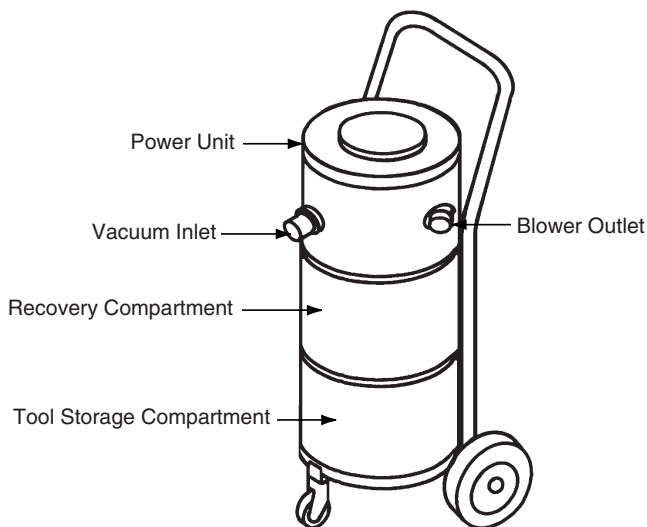

Figure 4. Blo-Vac™

Each Blo-Vac™ system is cart mounted for easy transporting around the job site. Each Blo-Vac™ unit has three compartments which are easily separated. The top section is the power unit, the center section is the recovery compartment, and the bottom section is storage for accessories. See Figure 4. The power unit and the recovery compartment may be unlatched from the tool storage compartment and used as a portable blower vacuum system. All Blo-Vac™ systems are equipped with a 1½" diameter x 8' long hose and seal-offs to fit ½" through 6" conduit.

The BV208DA Super Ultra Blo-Vac™ has a powerful three-stage motor fan section. The recovery capacity is 4½ gallons expandable to 9 gallons by using the tool storage compartment above the recovery compartment after removing the false bottom. Housings are made of high impact polypropylene.

7.0 USE AND OPERATION

The primary purpose of the GB/JetLine® Conduit Fishing System is to place a pull line in the conduit by the quickest and easiest means available. The GB/JetLine® Blower and Blo-Vac™ systems are low pressure, high volume machines that are easy and convenient to use.

7.1 Blowing Line in the Conduit

The GB/JetLine® Blower and Blo-Vac™ systems are designed to blow line in a "sealed" conduit such as EMT conduit with compression type couplings, rigid conduit with threaded joints, or PVC conduit with adhesive bonded joints. These types of conduit require very little effort to install a pull line with the Blower or Blo-Vac™ system.

There are some conduit runs that will be difficult or impossible to blow a line in, such as:

- Conduit containing hard packed sand, silt, debris or concrete.
- Conduit containing water with a head greater than the maximum water lift of the Blower or Blo-Vac™ system.
- Conduit with leaking or separated joints.
- Conduit with two sizes of duct connected by a reducer.
- Conduit with unsealed set screw couplings.
- Small diameter conduit of several hundred feet with multiple bends.

Let Gravity Help

When blowing line in conduit of tall buildings or underground duct, start at the highest elevation of the conduit entrance. In underground duct; water may have accumulated in low points of the run, and the blower may not be able to force it out. Start at the highest point.

7.2 Preparation

It is helpful to know the purpose for which the line is to be used once it has been blown into the conduit. This will aid the user in selecting the appropriate line for the job.

Knowing the approximate length of the conduit run will prevent selecting a line too short for the run. For example, if lightweight pull line is being placed in ¾" conduit with an estimated length of 195' to 200', select a 300' Power Saver™ line package for the run. An alternate solution would be to use a ¾" foam line carrier pulling bulk nylon line. Either selection would insure an adequate length of line.

7.3 Selecting the Pull Line

It is not possible to foresee all conduit situations that may be encountered, therefore, the following is presented as a guide in selecting pull line. Determine which best fits the situation; whether the line is to be used for conduit identification, pulling in a larger line or rope, pulling in wire or for wire pulls at a later date.

1. Identification of a conduit termination where multiple conduit runs originate from a single location. Recommended line: Power Saver™ Line Packages or Bulk Nylon Line.
2. Placing a line in the conduit for use at a later date. Recommended line: Small conduit ½", ¾" and 1" — Power Saver™ Line Packages, Bulk Nylon Line or PL232 Pull Line. Larger conduit 1¼" through 6" — Tag-Along™ Line Packages, PL232 or PL235.
3. Pulling in larger line, rope or steel winch cable. Recommended line: Small conduit — same as above. Larger conduit PL232, PL235 or Poly Rope.
4. Pulling wire in conduit. Recommended line: PL232, PL235 or Poly Rope.

7.4 Power Saver™ Line Packages

The Power Saver™ line package is the easiest and most versatile line that can be installed in conduit. The self-contained (no line carrier needed) 17 lb. breaking strength nylon line package comes in different lengths sized for ½", ¾" and 1" conduit. It dispenses a line as the package is blown or vacuumed through the conduit. The line may be used for identification of the conduit exit, pulling in a heavier pull line (PL series pull line or small rope).

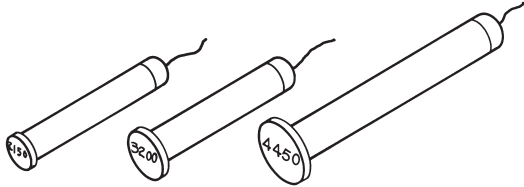

Figure 5. Power Saver™ Line Packages

Power Saver™ Line Packages		
Part #	Conduit Size	Length
LP2150	½"	150'
LP3200	¾"	200'
LP3300	¾"	300'
LP3450	¾"	450'
LP4200	1"	200'
LP4300	1"	300'
LP4450	1"	450'

7.5 Tag-Along™ Line Packages

The Tag-Along™ line package must be used with a line carrier (foam or inflatable) in 1¼" or larger conduit. The increased package diameter and length prevents the package from passing freely through or around bends in conduit less than 1¼". Once attached to the line carrier, the Tag-Along™ line package function and operation is similar to that of the Power Saver™ package. Breaking strengths are 22 lbs.

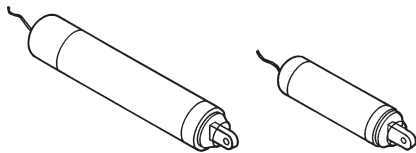

Figure 6. Tag Along™ Line Packages

Tag-Along™ Line Packages		
Part #	Length	Strength
LP2206T	400'	22 lbs
LP2208T	600'	22 lbs
LP2207T	800'	22 lbs

Bulk Nylon Line

JetLine® bulk nylon line is fed into the conduit through the seal-off feed through port. However, unlike the Power Saver™ and Tag-Along™ package, bulk line packages remain at the conduit entrance. Line is pulled into the conduit by one of the JetLine® line carriers. Bulk nylon line is supplied in 22 lb., 30 lb. and 100 lb. breaking strengths.

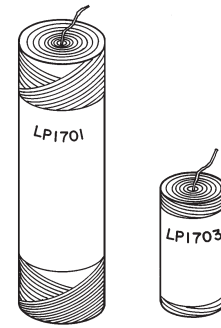

Figure 7. Bulk Nylon Line

Bulk Nylon Line		
Part #	Length	Strength
LP1701	1000'	100 lbs
LP1702	2000'	30 lbs
LP1703	1400'	22 lbs
LP1707*	1350'	100 lbs
LP1722	2200'	90 lbs

* Wound on cardboard tube, not center dispensing.

7.6 PL Series Pull Line

JetLine® linear stranded PL series pull lines are designed specifically for conduit fishing. These lines are made of strong polyolefin plastic that will not rust, rot or mildew. The coreless wound roll of knot free pull line makes center dispensing from the carton a convenient feature when feeding the pull line directly into the conduit through the seal-off.

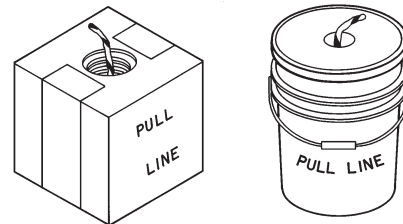

Figure 8. Dispensing Carton and Bucket

The PL Series are oval in shape and tend to flatten out in bends. The flattened edges reduce the abrasive and cutting effect in PVC conduit.

PL102 Pull Line - The 6500' roll of 190 lb. breaking strength pull line is fiberlaid polyolefin line (approx. ⅛" in diameter).

PL232 Pull Line - The 6500' roll of 200 lb. breaking strength pull line is oval in shape (approx. ⅜" x ⅝") will pass through the feed through port of all JetLine® seal-offs.

PL235 Pull Line - The 2200' roll of 500 lb. breaking strength pull line is oval in shape (approx. ⅜" x ⅝") will feed through the port of Catalog No. B26 large Dial-A-Line™ seal-off body.

PL-series Pull Line		
Part #	Length	Strength
PL231	1000'	100 lbs
PL102	6500'	190 lbs
PL232	6500'	210 lbs
PL235	2200'	500 lbs

Conduit Measuring Tape

JetLine® TT31 True Tape™ and ST40 Super True Tape™ provide an accurate means of measuring the length of conduit runs already in place. Both are marked in 1' increments.

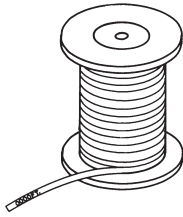

Figure 9. Conduit Measuring Tape

When measuring for wire length, measure from terminal to terminal, not from end of conduit. See Conduit Measuring Tape Table for allowances to be made for 90° bends, 45° offsets, and panel boxes.

Conduit Measuring Tape		
Part #	Description	Length
TT31	True Tape™	3000' roll
ST40	Super True Tape™	2750' roll

7.7 Seal-Offs

The GB/JetLine® seal-offs are the final connection between the blower or Blo-Vac™ hose and the conduit. Seal-offs attach to the JV07 or B26 Dial-A-Line™ body. The tapered seal-off cone (five sizes to fit ½" through 6" conduit) must be held firmly in the conduit when blowing or vacuuming line in conduit.

JV07 Dial-A-Line™ Body

The small JV07 Dial-A-Line™ body is used in conjunction with the BV12 Hose Adapter, accepts the JV08 Short Seal-Off, JV09 Long Seal-Off or the JV12 Seal-Off. The perforated dial plate on the JV07 is adjusted to feed pull line up to ⅜" diameter or for feeding TT31 True Tape™. Close off the feed port when Power Saver™ or Tag-Along™ line packages are used or when vacuuming.

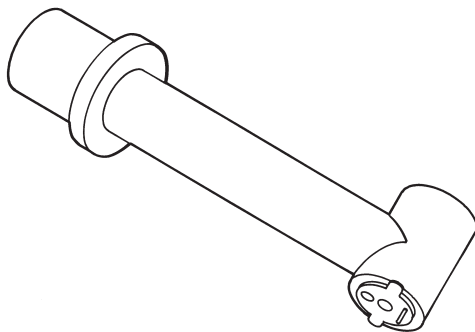

Figure 10. Dial-A-Line™ Seal-Off Body and Hose Adapter

JV08 Short Seal-Off

The JV08 Seal-Off is used in close quarters such as 2' x 4' electrical boxes, etc. It may be used on ½" through 1¼" conduit.

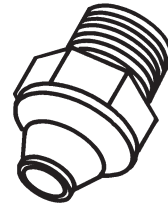

Figure 11. JV08 Short Seal-Off

JV09 Long Seal-Off

The JV09 Seal-Off is similar to the JV08, except for length, and is used to reach conduit in deep electrical boxes.

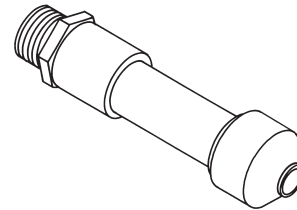

Figure 12. JV09 Long Seal-Off

JV12 Seal-Off

The JV12 Seal-Off fits conduit sizes 1¼" through 2½".

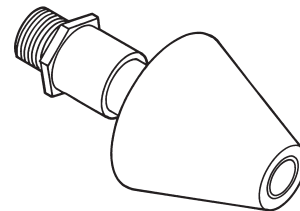

Figure 13. JV12 Seal-Off

B26 Dial-A-Line™ Body

The B26 is a large seal-off body that can be coupled directly to either the 1½" or 2½" hose assembly. It is used with the BV23 and BV24 seal-offs. The dial plate has a small hole for feeding pull line up to ⅜" diameter. The large hole is for larger pull line and rope up to ½" diameter. The slot is for feeding TT31 True Tape™ or the feed port may be closed off when using a Tag-Along™ line package with line carrier or when vacuuming.

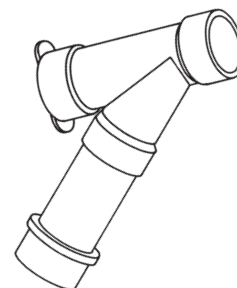

Figure 14. Dial-A-Line™ Seal-Off Body

BV23 and BV24 Seal-Off

The larger internal diameter of BV23 and BV24 seal-offs allows more efficient flow of air when used with high volume blowers and Blo-Vac™ systems. The BV23 and BV24 seal-offs are used in 1¼" through 2½" and 2½" through 6" conduit respectively.

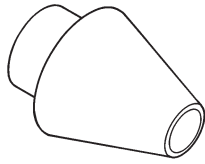

Figure 15. BV23 Short Seal-Off

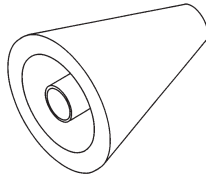

Figure 16. BV24 Seal-Off

7.8 Line Carriers

The line carrier is the movable "piston" that supplies the force necessary to pull the line through the conduit when propelled by the blower or Blo-Vac™ system. They are constructed of durable material and is reusable.

Foam Line Carriers

GB/JetLine® foam line carriers are manufactured in 12 sizes for use in conduit ½" through 6". The foam line carrier, as it travels through the conduit, will clean out water and loose debris providing the head of water is not greater than the maximum water lift of the blower or Blo-Vac™ power unit. Sizes for 1¼" through 6" conduit are provided with a pulling eye on one end and a hook on the other end. The hook provides a convenient means of attaching the Tag-Along™ line package. If pull line is used, it should be attached to the pulling eye.

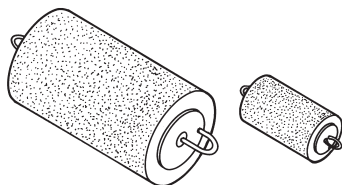

Figure 17. Foam Line Carriers

Foam Line Carriers			
Part #	Conduit Size	Part #	Conduit Size
FC1	½"	FC7	2½"
FC2	¾"	FC8	3"
FC3	1"	FC9	3½"
FC4	1¼"	FC10	4"
FC5	1½"	FC11	5"
FC6	2"	FC12	6"

The Inflatables® Line Carrier

The Inflatables® line carrier has less friction in the conduit and is faster running than the foam line carrier. The flexible nature of the line carrier allows it to inflate to the conduit diameter and pass over local obstructions that would stop a foam line carrier.

In large conduit 4", 5" and 6", the Inflatables® may lie against the conduit wall. It may be necessary to point the seal-off nozzle toward the inflatable sleeve to achieve initial inflation. This is accomplished by tilting the seal-off nozzle in the conduit entrance.

When vacuuming an inflatable in the conduit it may be necessary to fluff it out and shake it to achieve inflation.

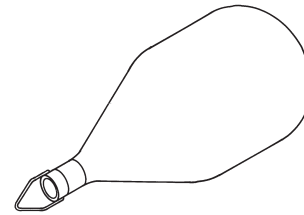

Figure 18. The Inflatables® Line Carrier

The Inflatables® Line Carriers	
Part #	Conduit Size
F125	¾", 1" and 1¼"
F250	1½", 2" and 2½"
F400	3", 3½" and 4"
F600	5" and 6"

Plastic Line Carriers

The GB/JetLine® slotted double skirted plastic line carriers were developed for the Blo-Vac™ conduit fishing systems for use in long, single bore underground ducts. The low friction properties of the plastic makes it a fast running line carrier. If the line carrier encounters a blockage where it cannot get through, the slotted skirt allows the line carrier to be pulled out past joints or steps in the duct. A hard tug on the pull line will cause the petals to turn inside out allowing for easy withdrawal.

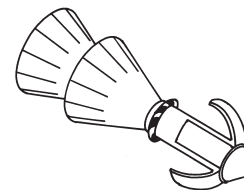

Figure 19. Missile Line Carrier

Plastic Line Carriers			
Part #	Conduit Size	Part #	Conduit Size
M2000	2"	M4000	4"
M2500	2½"	M5000	5"
M3000	3"	M6000	6"
M3500	3½"		

7.9 Blowing or Vacuuming Through Conduit

Select the Power Saver™ line package for size and length of line to fit the conduit. It is recommended that you flex the package back and forth two or three times to loosen it. This will make the line easier to dispense.

Blowing a line in the conduit

1. Insert the hose in the blower side of the Blo-Vac™ power unit.
2. Insert the BV12 hose adapter in the other end of the hose. Screw the handle end of the JV07 Dial-A-Line™ body into the hose adapter. Select either the JV08 or JV09 seal-off and screw it into the JV07. See Figures 20, 21 and 22.

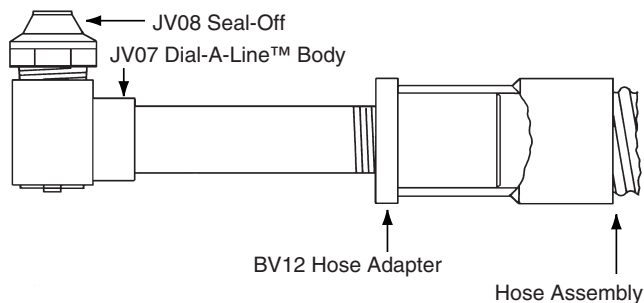

Figure 20. Blowing a line in the conduit

3. Pull out approximately 2' of line and hold on to trailing end.
4. Insert the line package in the conduit — foam tip first.
5. Hold the seal-off cone firmly in the conduit entrance and turn on the blower. Blow the line package through the conduit.
6. It is recommended that the ends of the line be tied off, to prevent it from being accidentally pulled into the conduit.

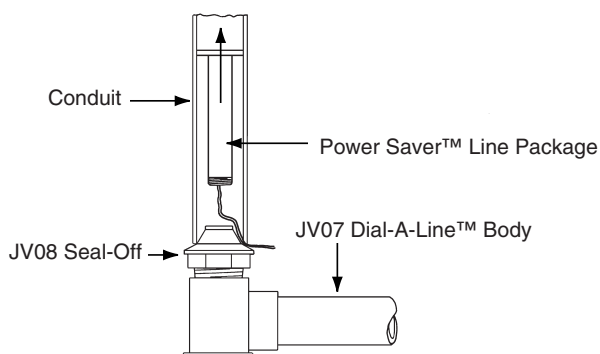

Figure 21. Blowing a line in the conduit

Vacuuming a line in the conduit

1. Insert the hose in the vacuum side on the Blo-Vac™ power unit.
2. Assemble the hose and seal-off as in Item 2 above.
3. At the far end of the conduit run, pull out approximately 2' of line and tie off the trailing end of the line.
4. Insert the line package in the conduit — foam tip first.
5. Return to the other end of the conduit and power unit.
6. Hold the seal-off cone in the conduit and turn on the power unit and vacuum the line package through the conduit.

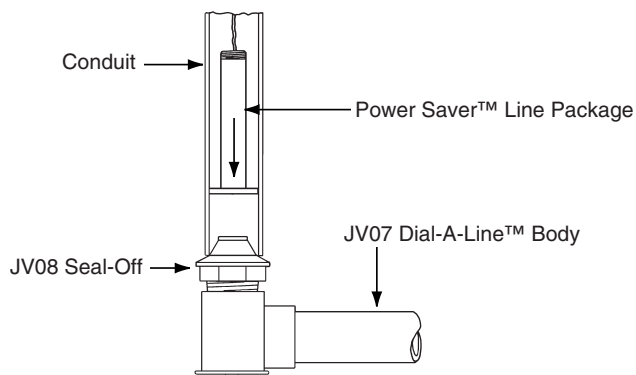

Figure 22. Blowing a line in the conduit

Tag-Along™ Line Package

Tag-Along™ line packages perform the same function as Power Saver™ line packages except they are used in 1½" diameter and larger conduit. Tag-Along™ package must be used with a line carrier to supply the pulling force.

Select the Tag-Along™ line package and a line carrier either foam or inflatable that fits the conduit diameter and proceed as follows:

If a foam line carrier is selected—

1. Attach the Tag-Along™ line package plastic eye to hook. Pull out approximately 2' of line. Tie off the ends of the line to prevent it from being accidentally pulled into the conduit.
2. Insert the foam line carrier and Tag-Along™ package in the conduit.
3. Select the seal-off that best fits the conduit — JV07 Dial-A-Line™ body with the JV12 seal-off or the B26 Dial-A-Line™ body with the BV23 or BV24 seal-off.
4. Hold the seal-off rubber cone firmly in the conduit and turn on the power unit. The run time will be longer than that for the Power Saver™ line package because of the larger conduit and greater volume of air required. However, the run time in 3" and 4" conduit 200' to 300' long should be complete in 10 to 15 seconds.

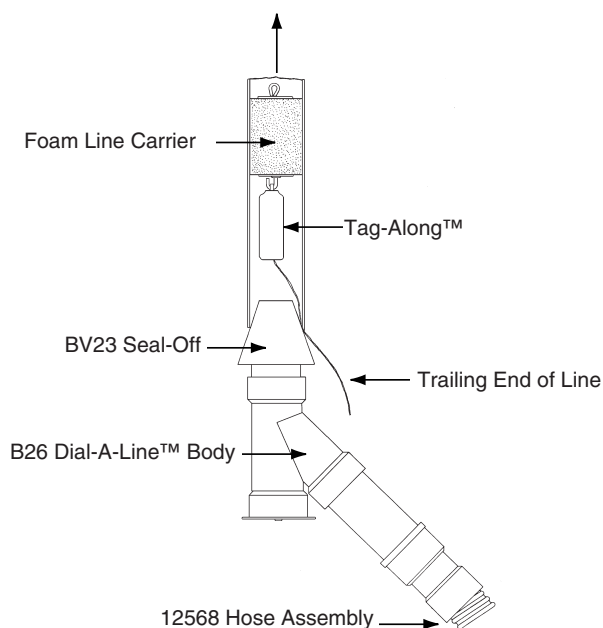

Figure 23. Blowing a Tag-Along™ line in the conduit

If The Inflatables® line carrier is used—

1. Select The Inflatables® line carrier and attach the Tag-Along™ line package to the wire. Pull out approximately 2' of line and hold on to the trailing end.
2. Unfurl The Inflatables® line carrier and place it in the conduit — bag portion first. See Figure 24.

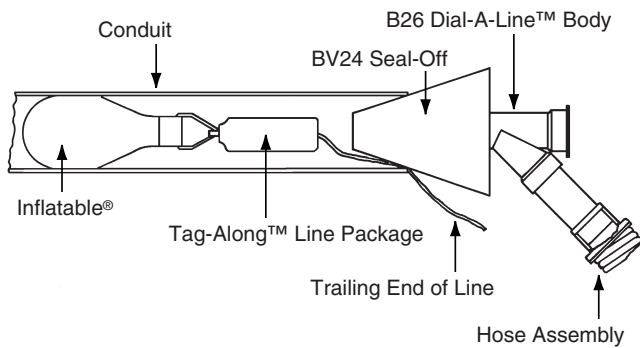

Figure 24: Blowing a Tag-Along Line Package in conduit with the Inflatables®

3. In large conduit: (4", 5" and 6" diameter), it may be necessary to point the seal-off nozzle at the plastic sleeve of the Inflatable® to achieve initial inflation. This is accomplished by tilting the seal-off in the conduit entrance. Otherwise, the Inflatable® in its collapsed state may allow the stream of air to blow past it.

Blowing Pull Line in the Conduit

All GB/JetLine® systems may be used to blow pull line or nylon line in the conduit. Position Blo-Vac™ systems in a location that allows good access to the conduit entrance. See Figure 25.

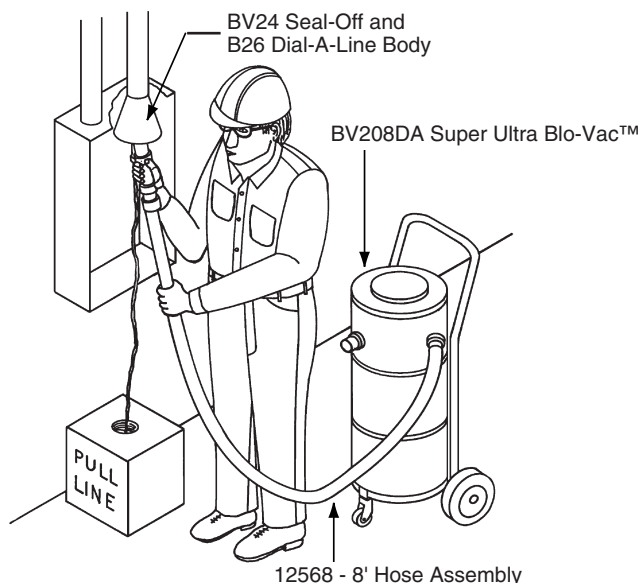

Figure 25: Blowing Pull Line in the Conduit

Set-up as follows:

1. Insert the hose in the power unit blower port.
2. Select the JV07 Small Dial-A-Line™ body that accepts the JV08, JV09 or JV12 Seal-off for conduit sizes ½" through 2½" or the B26 Large Dial-A-Line™ body that accepts the BV23 or BV24 Seal-off for conduit sizes ¼" through 6".

3. Connect the hose to the Dial-A-Line™ body and thread the pull line through the feed port. See Figures 26, 27 and 28.

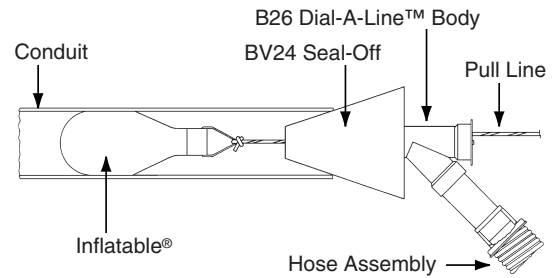

Figure 26. Blowing line in conduit with the Inflatables®

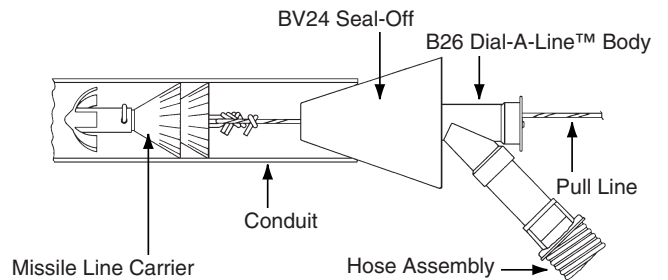

Figure 27. Blowing line in conduit with the Missile Line Carrier®

4. Select the appropriate size line carrier and tie the pull line securely to the line carrier to prevent loss of the line in the conduit.
5. Insert the line carrier in the conduit and hold the seal-off firmly in the conduit entrance and turn on the blower.

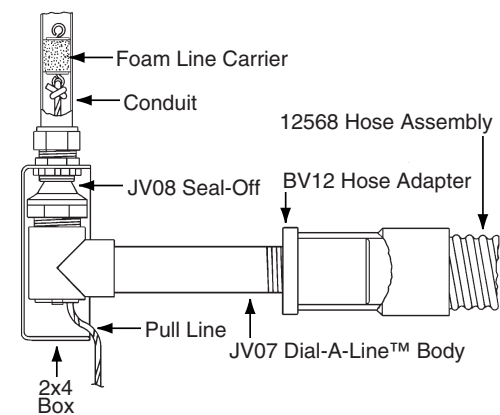

Figure 28. Blowing line in conduit with the Foam Line Carrier®

Vacuuming Pull Line in the Conduit

1. Insert the hose in the vacuum port.
2. Select the JV07 small Dial-A-Line™ body that accepts the JV08, JV09 or JV12 Seal-off for conduit sizes ½" through 2½" or the B26 Large Dial-A-Line™ body that accepts the BV23 or BV24 Seal-off for conduit sizes ¼" through 6".
3. Connect the hose to the Dial-A-Line™ body.
4. Place the pull line at the far end of the conduit.
5. Select the appropriate line carrier and tie the pull line securely to the line carrier.
6. Insert the line carrier in the conduit and turn on the power unit.

8.0 Maintenance

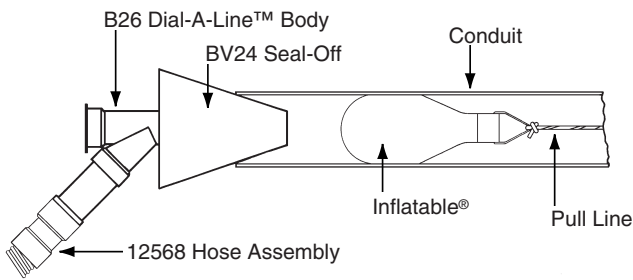

Figure 29. Vacuuming Line in Conduit with the Inflatables®

The Blowers and Blo-Vac™ systems should require very little maintenance. If the unit should require service, see instructions below.

Blower overheating occurs when attempting to blow line in blocked conduit or a duct filled with water having a head greater than the water lift capability of the blower. See 5.0 Technical Specifications, GB/JetLine® Blowers Table.

The 1261 and B3000 Blowers have an automatic thermal overload switch built into the motor. If overheating occurs, the switch will turn the motor off. After a cool-down period of 15 to 30 minutes, the motor will automatically re-set. The motor can be restarted.

Blo-Vac™ power units are equipped with a perforated filter screen, located on the under side of the motor compartment. Occasionally the screen becomes clogged with lint and dust and it should be cleaned to maintain maximum air flow.

Vacuuming Dirt and Water — Each Blo-Vac™ comes with a cloth filter bag that must be used when vacuuming dirt and water. Use as follows:

1. Release the latches securing the top and center together.
2. Remove the filter bag from the bottom tool storage section. Slide the filter bag onto the intake canister located on the bottom of the motor. The filter bag prevents dust from entering the motor. Dust and dirt will damage the motor and cause premature failure.
3. After use, clean the filter bag by shaking off the excess dirt and store the clean bag in the lower compartment.
4. The Blo-Vac™ is equipped with a ball float to prevent water from entering the motor. If the ball float seals the motor inlet, the motor will sound different from usual. Immediately turn the unit off. Empty the recovery section and check the inlet screen for lint and dirt. Clean and reassemble the Blo-Vac™ sections.

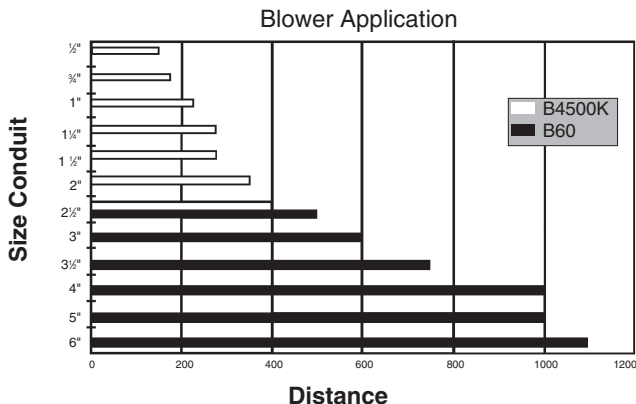

Blo-Vac™ Application

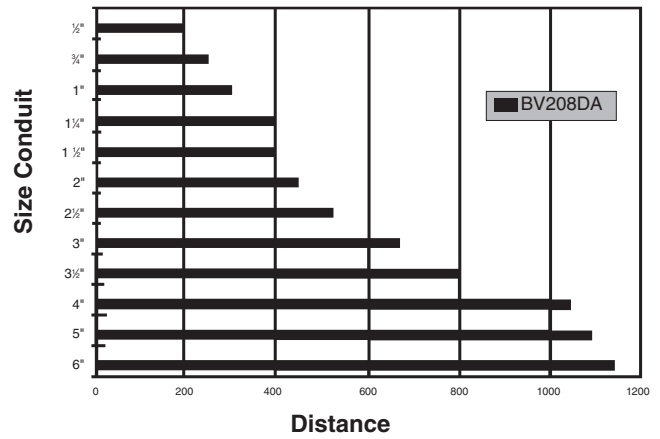

9.0 Jetline® Systems

9.1 B4500K Line Shooter™ Blowing System

Handles conduit 1/2" to 6".

- Includes lightweight Line Shooter™ hand-held blowgun and flexible coupling extension for hard-to-reach conduit openings.
- Compact #1261 blower unit delivers a powerful punch, yet carries hands-free with shoulder strap. Durable high-impact housing stands up to job site abuse.
- Exclusive line drag key controls line tension to prevent overblowing and line pile-up.
- Includes 1,000' of 100 lb-test Poly-Pull™ line.
- Handy tool box holds entire system.
- Line Keeper™ slotted disc securely retains line in housing; prevents lost lines.
- Specifications: 3.25 max. psi; 90 cfm; 1.2 hp motor.
- 115 V AC; 7 A.

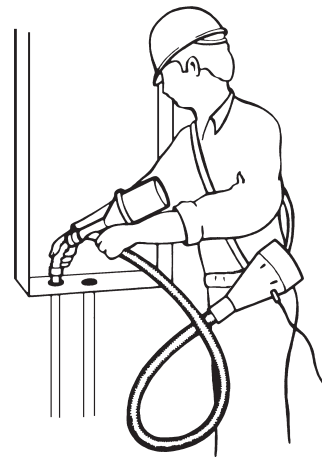

Figure 30. Blowing Line in Conduit with the Line Shooter™ Blower System

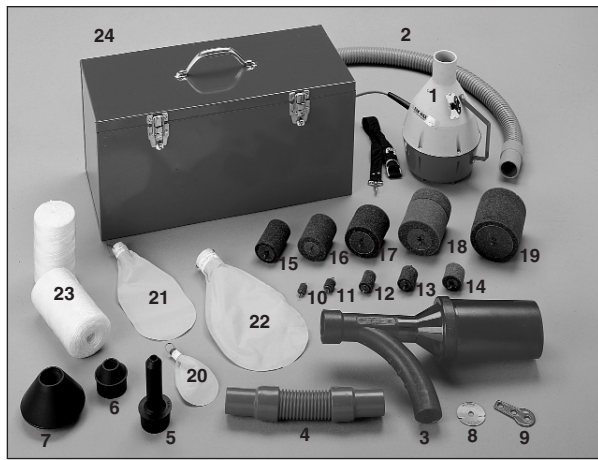

Figure 31. Line Shooter™ Blowing System

Line Shooter™ Blowing System			
Part #	Description	Weight	ID #
1261	Power Unit	9 lbs	1
BR-1503	3' x 1½" Heavy-duty Hose	1.6 lbs	2
BR-1549	Canister & Handle Assembly	1.8 lbs	3
BR-1060	1' Heavy-duty Hose (1½" dia)	.9 lb	4
BR-1003	Long Seal-off for ½" - 1" conduit	.4 lb	5
BR-1004	Seal-off for 1¼" - 1½" conduit	1.3 lbs	6
BR-1005	Seal-off for 2" - 4" conduit	1.2 lbs	7
BR-1650	Line Keeper™ Disc	.2 lb	8
BR-1651	Line Drag Key	.2 lb	9
FC1	Foam Line Carrier for ½" conduit	.1 lb	10
FC2	Foam Line Carrier for ¾" conduit	.1 lb	11
FC3	Foam Line Carrier for 1" conduit	.1 lb	12
FC4	Foam Line Carrier for 1¼" conduit	.1 lb	13
FC5	Foam Line Carrier for 1½" conduit	.1 lb	14
FC6	Foam Line Carrier for 2" conduit	.1 lb	15
FC7	Foam Line Carrier for 2½" conduit	.1 lb	16
FC8	Foam Line Carrier for 3" conduit	.1 lb	17
FC9	Foam Line Carrier for 3½" conduit	.1 lb	18
FC10	Foam Line Carrier for 4" conduit	.1 lb	19
F125	Line Carrier for ¾", 1" & 1¼" conduit	.1 lb	20
F250	Line Carrier for 1½", 2" & 2½" conduit	.1 lb	21
F400	Line Carrier for 3", 3½" & 4" conduit	.1 lb	22
PL231	Poly-Pull™ Line, 1,000' (100 lb test)	1.3 lbs	23
106	Carrying Case	15.7 lbs	24

Optional Accessories		
Part #	Description	Weight
BR-1006	Seal Adapter for 5" & 6" conduit	1.1 lbs
BR-1500AC	Air Compressor Valve Assembly	1.8 lbs
LP-1722	Nylon Bulk Line, 2,200' (90 lb test)	1.3 lbs

9.2 B60 Jetline® Super Blower™ System

The most powerful blower system in the market.

- Blower unit delivers 275 cfm at 3 psi – more than enough to blow ½" Poly-Pull™ rope 1000' or more through conduit up to 6" diameter.
- Lightweight (35 lbs) and compact (24" x 7½" x 8¼") power unit can be hand-carried right up to the work area.
- Extra-long 25' hose allows power unit to be located outside the manhole or vault.
- All work is done from one end of the conduit, permitting one-person operation. Works on 115 V AC power.
- System includes patented Dial-A-Line™ Seal-Off System; eliminates extra steps by allowing simple "dial" selection of feed-thru opening size for up to ½" pull rope.
- May use pull rope and True Tape™ conduit measuring tape simultaneously.
- 115 V AC, 23 A; Power Consumption 2.65 kw.
- Specifications: 4 max. psi; 150 cfm; 3 motors (1½ hp each).

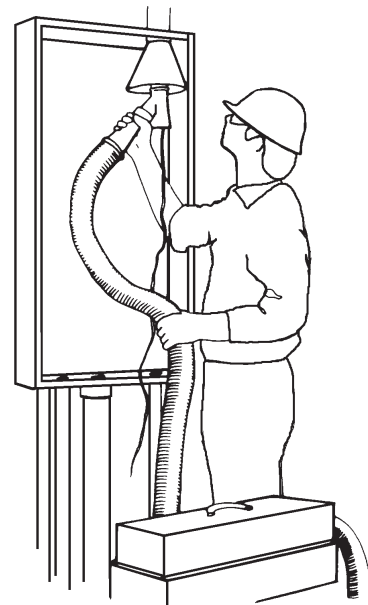

Figure 32. Blowing Line in Conduit with the Jetline® Super Blower™ System

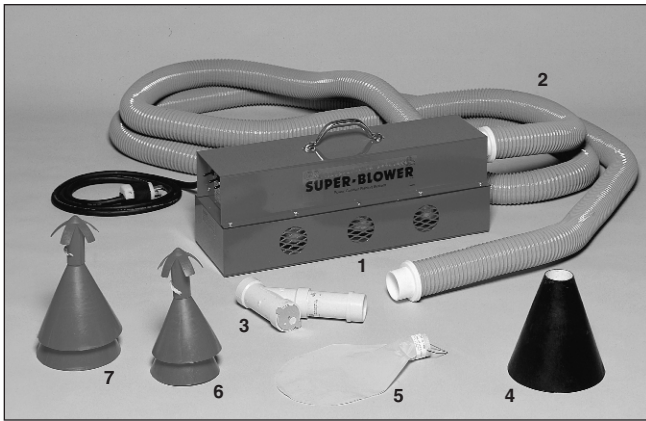

Figure 33. Jetline® Super Blower™ System

Jetline® Super Blower System			
Part #	Description	Weight	ID #
B3000	Power Unit	34 lbs	1
126025	25' x 2½" Heavy-duty Hose	12 lbs	2
B26	Large Dial-A-Line™ Seal-Off Body	.7 lb	3
BV24	Seal-Off for 2½" - 6" conduit	3.3 lbs	4
F400B	Line Carrier for 3", 3½", 4" conduit	.1 lb	5
M5000	5" Plastic Line Carrier	.4 lb	6
M6000	6" Plastic Line Carrier	.5 lb	7

REPAIR AND SERVICE INSTRUCTIONS: For repair service and parts contact your nearest Gardner Bender Service Center. The Gardner Bender Service Center will provide complete and prompt service on all Gardner Bender products.

<p>PARTS AND SERVICE: For quality workmanship and genuine Gardner Bender parts, select an Authorized GB Service Center for your repair needs. Only repairs performed by an Authorized Service Center displaying the official GB Authorized sign are backed with full factory warranty. Contact Gardner Bender (414)352-4160 for the name of the nearest GB Authorized Service Center.</p>	<p>WARRANTY: Gardner Bender warrants its product against defects in workmanship and materials for 1 year from date of delivery to user. Chain is not warranted. Warranty does not cover ordinary wear and tear, abuse, misuse, overloading, altered products or use of improper fluid.</p>	<p>WARRANTY RETURN PROCEDURE: When question of warranty claim arises, send the unit to the nearest GB Authorized Service Center for inspection, transportation prepaid. Furnish evidence of purchase date. If the claim comes under the terms of our warranty the Authorized Service Center will REPAIR OR REPLACE PARTS AFFECTED and return the unit prepaid.</p>
--	---	---



PO Box 3241 • Milwaukee, WI 53201-3241 • 414-352-4160 • Fax 414-352-2377
 6615 Ordan Drive • Mississauga, Ontario L5T 1X2 • 905-564-5749 • Fax 905-564-0305

RPS-0106 01/02