

If all of these conditions are checked to be fine and your instrument still does not operate properly then send it back freight prepaid to:

5/2000

Form #243

A.W. Sperry Instruments, Inc.

Hauppauge, NY 11788-2075

Include all accessories and a note explaining what is wrong with the instrument. Should you require an estimate please indicate "ESTIMATE ONLY" on your note. Be certain to include your return address and day time phone number should we need to contact you.

LIFETIME LIMITED WARRANTY

The attention to detail of this fine snap-around instrument is further enhanced by the application of A.W. Sperry's unmatched service and concern for detail and reliability. These A.W. Sperry snap-arounds are internationally accepted by craftsmen and servicemen for their unmatched performance. All A.W. Sperry's snap-around instruments are unconditionally warranted against defects in material and workmanship under normal conditions of use and service; our obligations under this warranty being limited to repairing or replacing, free of charge, at A.W. Sperry's sole option, any such A.W. Sperry snap-around instrument that malfunctions under normal operating conditions at rated use 1

REPLACEMENT PROCEDURE

Securely wrap the instrument and its accessories in a box or mailing bag and ship prepaid to the address below. Be sure to include your name and address, as well as the name of the distributor, with a copy of your invoice from whom the unit was purchased, clearly identifying the model number and date of purchase.

A.W. SPERRY INSTRUMENTS INC.
ATT: Customer Service Dept.

Hauppauge, NY 11788-2075

1 The warranty is not applicable if the instrument has been: misused, abused, subjected to loads in excess of specifications, has had unauthorized repair or has been improperly assembled or used.

* Note: Recommended calibration interval should not exceed one year. Calibration service charges are not covered under terms and conditions of warranty.

A.W. SPERRY INSTRUMENTS, INC.

Hauppauge, NY 11788-2075

Phone 800-645-5398 TOLL-FREE or 631-231-7050

FAX: 631-434-3128

Printed in Taiwan

Operating Instructions

DIGISNAP™ DIGITAL SNAP-AROUND VOLT-OHM-AMMETER MODELS DSA-600, DSA-600A, DSA-600P

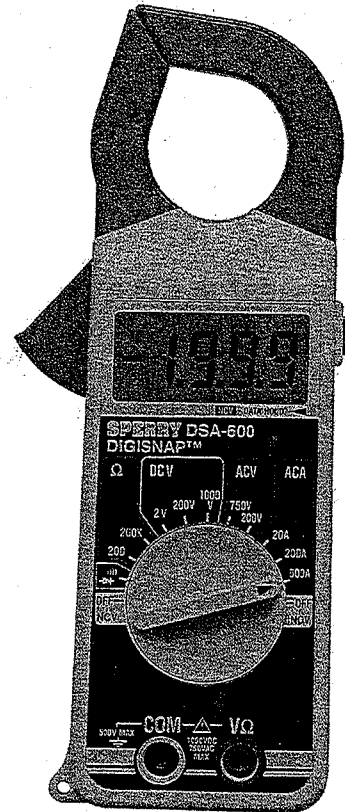

A.W. SPERRY INSTRUMENTS, INC.

210 Joshua's Path, HAUPPAUGE, N.Y. 11788-2075
800-645-5398 or 631-231-7050

FAX: 631-434-3128

SEC-1 FEATURES

- Limited lifetime warranty.
- Tear drop shaped jaws.
- Industry standard safety test leads.
- Recessed safety designed input terminals.
- "Data/Peak-Hold" switch (DSA-600P ONLY).
- "Data Hold" switch (DSA-600, DSA-600A ONLY).
- Overload protection on all ranges.
- Instant continuity buzzer.
- DC voltage range
- Diode test.

SEC-2 SPECIFICATIONS

DISPLAY:	3-3/4 (3-1/2) DIGIT LCD, maximum reading 3999, 1999 with automatic sign, AC, Batt and hold annunciators
OVERRRANGE INDICATION:	MSB (highest) digit of "OL" or 1 (-1) is displayed.
LOW BATTERY:	The is displayed (E) when the battery voltage drops below the operating voltage.
MEASUREMENT RATE:	3 measurements per second nominal
OPERATING TEMPERATURE:	0°C to +45°C (32°F to 122°F), 0-70% RH.
STORAGE TEMPERATURE:	-20°C to +60°C (0°F to 140°F), 0-80% RH with battery removed.
ACCURACY:	Accuracy specifications at 23±5°C less than 75% RH.
POWER:	9V transistor type battery (NEDA 1604) AWS Part #B-4.
DIMENSION:	7.5" (19.2cm) long 3.2" (8.2cm) wide 1.3" (3.3cm) high.
WEIGHT:	270g (9.4oz.) including battery.

2-1 ELECTRICAL SPECIFICATION

Accuracies are ±(reading plus number of digits). At 23±5°C less than 75% RH.

AC CURRENT			
Range	Resolution	600,600A	600P
40A, (20A**)	10mA	**	*
400A, (200A**)	100mA	**	*
600A	1A	**	*
Accuracy	± 1.5% RDG + 4 DGTS at 50-60Hz ± 2.0% RDG + 5 DGTS at 40-1KHz ON 40A (20A**) range 50-60Hz ± 1.5% RDG + 4 DGTS 40-1KHz ± 3.0% RDG + 5 DGTS		
OL-Protection	1200VDC/800VAC on all range		
AC VOLTAGE			
Range	Resolution	600,600A	600P
400V, (200V**)	100mV	**	*
750V	1V	*	*
Accuracy	± 1.0% RDG + 4 DGTS at 50-60Hz ± 1.5% RDG + 4 DGTS at 40-1KHz		
Input Impedance	10MΩ		
OL-Protection	1200VDC/800VAC on all range		

DC VOLTAGE

Range	Resolution	600,600A	600P
4V, (2V**)	1mV	**	*
400V, (200V**)	100mV	**	*
1000V	1V	*	*
Accuracy	± 0.5% RDG + 1 DGT		
Input Impedance	10MΩ		
OL-Protection	1200VDC/800VAC on all range		

RESISTANCE

Range	Resolution	600,600A	600P
400Ω, (200Ω**)	0.1Ω	**	*
400KΩ, (200KΩ**)	100Ω	**	*
Test Voltage	400Ω (200Ω) Range 3.2V MAX 400KΩ (200KΩ) Range 0.3V MAX.		
OL-Protection	500VDC/350VAC on all range		
Accuracy	± 1.0% RDG + 3 DGT		

DIODE TEST

Test Current	Test Voltage	600,600A	600P
1.0 ± 0.6mA	3.4V MAX	*	*
OL-Protection	500VDC/350VAC		

CONTINUITY BEEPER

Threshold	Response Time	600,600A	600P
Approx. 100	100 ms	*	*
OL-Protection	500VDC/350VAC		

NON CONTACT VOLTAGE (NCV TEST)

Range	600,600A
Range Test	100-600VAC max to ground *
Frequency	50/60Hz
Dielectric Strength	2000V, 1 minute, 100uA or less during dielectric strength.

SEC-3 FRONT PANEL CONTROLS AND INDICATORS

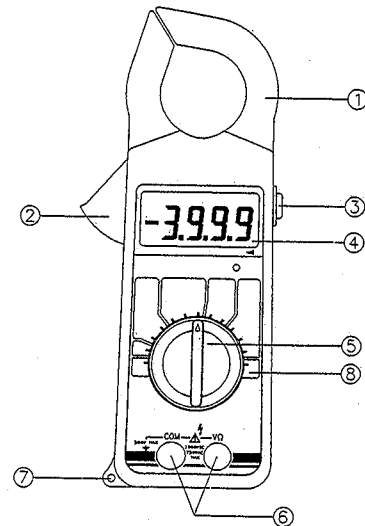

Fig. 1

1. TRANSFORMER JAWS: Pick up the AC current flowing through the conductor.
2. TRIGGER: Press the trigger to open the transformer jaws. When the trigger is released, the jaws will close again.
3. "DATA/PEAK-HOLD" SWITCH: A push switch (Push On/Pull Off). Data-Switch will freeze reading when depressed. (Data-Hold exchange to Peak-Hold automatically after 5-10 sec.) (Peak Hold not on models DSA-600, DSA-600A).
4. LCD DISPLAY: A 3-3/4 (3-1/2) display indicates measured values, and features symbols indicating function, Data/Peak-Hold, low battery, continuity.
5. FUNCTION SELECTOR.
6. INPUT JACKS (V and COM): Test leads are inserted into these jacks for voltage measurements and continuity checks.
7. DROP-PROOF WRIST STRAP: Prevents the instrument from slipping off the hand while in use.
8. NCV: Non Contact Voltage Detection.

SEC-4 SAFETY PRECAUTIONS:

The following safety precautions must be observed to insure maximum personal safety during the operation, service and repair of this meter:

1. Read these operating instructions thoroughly and completely before operating your meter. Pay particular attention to WARNINGS which will inform you of potentially dangerous procedures. The instructions in these warnings must be followed.
2. Always inspect your meter, test leads and accessories for any sign of damage or abnormality before every use. If any abnormal conditions exist (eg. broken test leads, cracked cases, display not reading, etc.), do not attempt to take any measurements. Refer to Return for Repair section.
3. Do not expose the instrument to direct sun light, extreme temperature or moisture.
4. Never ground yourself when taking electrical measurements. Do not touch exposed metal pipes, outlets, fixtures, etc., which might be at ground potential. Keep you body isolated from ground by using dry clothing, rubber shoes, rubber mats, or any approved insulating material.
5. To avoid electric shock use CAUTION when working with voltages above 40 Vdc or 20 Vac. Such voltages pose a shock hazard.
6. Never exceed the maximum allowable input value of any function when taking a measurement. Refer to the specifications for maximum inputs.
7. Never touch exposed wiring, connections or any live circuit when attempting to take measurements.
8. Do not attempt to operate this instrument in an explosive atmosphere (i.e. in the presence of flammable gases or fumes, vapor or dust).
9. When testing for the presence of voltage, make sure the voltage function is operating properly by reading a known voltage in that function before assuming that a zero reading indicates a no-voltage condition. Always test your meter before and after taking measurements on a known live circuit.
10. Calibration and repair of any instrument should only be performed by qualified and trained service technicians.
11. Do not attempt calibration or service unless trained and another person, capable of rendering first aid and resuscitation is present.
12. Do not install substitute parts or perform any unauthorized modification of the instrument. Return the instrument to A.W. Sperry Instruments for service and repair to insure that safety features are maintained.
13. Remember: Think safety, Act safely.

SEC-5 OPERATION

Before making any measurements read section-Safety Precautions. Always examine the instrument and accessories to be used with the instrument for damage contamination (excessive dirt, grease etc.) and defects. Examine the test leads for cracked or frayed insulation and make sure the lead plugs fit snugly into the instrument jacks. If any abnormal condition exist, do not attempt to take any measurements.

5-1 AC CURRENT MEASUREMENT

WARNING

These Snap-Arounds are designed to take current measurements on circuits with a maximum voltage difference of 500VAC between any conductor and ground potential. Using the Snap-Around for current measurements on circuits above this voltage may cause electric shock, instrument damage and/or damage to the equipment under test. Before measuring current make certain that the test leads are removed from the instrument.

WARNING

The Snap-Around is overload protected up to 500 VAC for up to 1 min. Do not take current readings on circuits where the maximum current potential is not know. Do not exceed the maximum currents that this instrument is designed to measure.

1. Set Function Switch to ACA 600A Range
2. Make sure that "Data/Peak-Hold" switch is not on
3. Open transformer jaws by pressing against the trigger.
4. Enclose one conductor in transformer jaws and release trigger. Jaws should be completely closed before taking a reading.
5. The reading will be indicated on the display
6. To hold the display press the "Data/Peak-Hold" switch
7. To obtain Peak readings (Model DSA-600P) press the "Data/Peak-Hold" switch and continue to depress for 5-10 seconds. Data Hold will now change to Peak Hold.

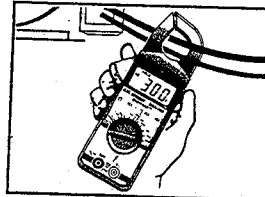

WRONG

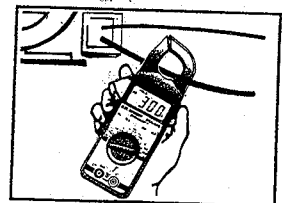

CORRECT

Fig. 2

5-2 DC VOLTAGE MEASUREMENTS

1. Connect red test lead to VΩ input connector and black test lead to COM input connector.
2. Set Function/Range Switch to desired DC and V position. If magnitude of voltage is not known, set switch to highest range and reduce until a satisfactory reading is obtained.
3. Turn off power to the device or circuit being tested and discharge all capacitors
4. Connect the test leads to the device or circuit being measured. (Fig. 3)
5. Turn on power to the device or circuit being measured. Voltage value will appear on the digital display along with the voltage polarity.
6. Turn off power to the device or circuit being tested and discharge all capacitors prior to disconnecting test leads.

5-3 AC VOLTAGE MEASUREMENTS

1. Connect red test lead to $V\Omega$ input connector and black test lead to COM input connector.
2. Set Function/Range Switch to desired AC and V position. If magnitude of voltage is not known, set switch to highest range and reduce until a satisfactory reading is obtained.
3. Turn on power the device or circuit being tested and discharge all capacitors.
4. Connect the test leads to the device or circuit being measured. (Fig 4)
5. Turn off power to the device or circuit being measured. Voltage value will appear on digital display.
6. Turn off power to the device or circuit being tested and discharge all capacitors prior to disconnecting test leads.

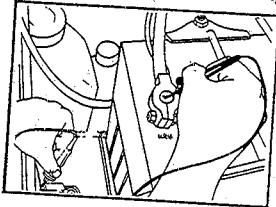

Fig 3

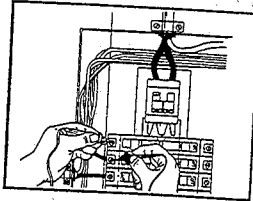

Fig 4

5-4 RESISTANCE MEASUREMENTS

WARNING

Attempting resistance or continuity measurements on live circuits can cause electrical shock, damage to the instrument and damage to the equipment under test. Resistance measurements must be made on de-energized (DEAD) circuits only for maximum personal safety. The electronic overload protection installed in this instrument will reduce the possibility of damage to the instrument but not necessarily avoid all damage or shock hazard.

All resistance ranges on the instrument are low-power ohms except for the 200-ohm range. The low power ohm allows accurate measurements of in-circuit resistance, since the test voltage is below that necessary to turn on a diode junction.

1. Connect red test lead to $V\Omega$ input connector and black test lead to the COM input connector.
2. Set Function/Range Switch to desired ohm position. If magnitude of resistance is not known, set switch to highest range and reduce until a satisfactory reading is obtained.
3. If the resistance being measured is connected to a circuit, turn off power to the circuit being tested and discharge all capacitors.
4. Connect test leads to the circuit being measured (Fig 5) When measuring high resistance, be sure not to contact adjacent points even if insulated, because some insulators have a relatively low insulation resistance.
5. Read resistance value on digital display if a high resistance value is shunted by a large value of capacitance, allow digital LCD to stabilize.

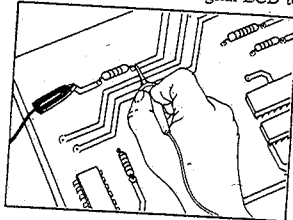

Fig 5

5-5 DIODE TEST MEASUREMENTS

The special Diode Test Function allows relative measurements of forward voltage drops across diodes.

5-5-1 DIODE TESTS

1. Connect red test lead to the $V\Omega$ input connector and black test lead to the COM input connector.
2. Set Function/Range Switch to the diode test position.
3. If the semiconductor junction being measured is connected to a circuit, turn off power to circuit being tested and discharge all capacitors.
4. Connect test leads to the device.
5. Read forward value on digital display.
6. If the digital display reads overrange OL reverse the lead connections. The placement of the test leads when the forward reading is displayed indicates the orientation of the diode. The red lead is positive and the black leads is negative. If overrange OL is displayed with both lead connections, the junction is open. If a low-reading (less than 1000) is obtained with both lead connections, the junction is shorted internally or (if junction is measured in a circuit) the junction must be disconnected from the circuit in order to verify its operation.

5-6 CONTINUITY MEASUREMENTS

1. Set the selector switch to the position.
2. Continuity between probe tips will be indicated by the audible buzzer when resistance is below 100 ohm.

5-7 NON CONTACT VOLTAGE (NCV) MEASUREMENTS (DSA-600, 600A only)

1. Switch to "OFF", push "NCV" button.
2. Check device with a known live current source (wall receptacle or cord). The Volt Sensor is operative if the red LED light remains on and the "beep" sound continues in colsem proximity of a cord connected to a power source.

SEC-6 BATTERY REPLACEMENT

WARNING

To avoid electric shock, disconnect measuring terminals before removing cover.

1. The battery is installed inside the case.
2. Remove the screw on the back of the battery cover for battery replacement.

SEC-7 RETURN FOR REPAIR

Before returning your instrument for repair make sure the failure to operate is not caused by

- 1) Weak or de-energized battery
- 2) Broken test leads
- 3) Data Hold or Peak Hold is on